



## Steel Railing Installation Instruction

### PRE-INSTALLATION CRITICAL POINTS

For a safe and reliable installation of the RailMaster Steel Railing System, it is imperative to adhere to the provided instructions and use the proper tools and equipment.

Always wear safety glasses when cutting, drilling, and assembling the product.

The installer is solely responsible for ensuring compliance with all local building codes and safety requirements and obtaining all required building permits. Master Halco® accepts no liability or responsibility for improper or unsafe installation of this product.

The installer is responsible for determining the specific requirements for each unique railing application and for ensuring that RailMaster Steel Railing is suitable for the intended use.

RailMaster Steel Railing is designed and tested as a complete system and should be used in this manner. It is not meant to be used in combination with other railing systems.

It is essential to always secure the post to the deck framing and never attach it to the deck boards alone.

After cutting, ensure all metal shavings are removed and any sharp edges are filed. Apply two coats of RailMaster Black Touch-up Paint to the cut area, allowing sufficient drying time before proceeding with the installation.

Improper installation of this product can lead to personal injury, impact the performance of the railing system, and void the warranty.



**ESR-5479**



SCAN TO  
LEARN MORE!

# Steel Railing Installation Instruction

## - TOOLS & MATERIALS NEEDED

### TOOLS:

- Drill
- Safety glasses
- Hacksaw or metal cutting saw
- T25 Driver
- T25 Torx Bit
- 1/8" and 3/16" Drill bits
- Level
- Measuring tape
- Clamp grip x4
- Chalk Line
- 3/8" Diameter fasteners
- Shims
- Rubber mallet
- Pencil
- RailMaster Black Touch up Paint

### MATERIALS:

- Post Kits
- Panels
- Angle Bracket Kits

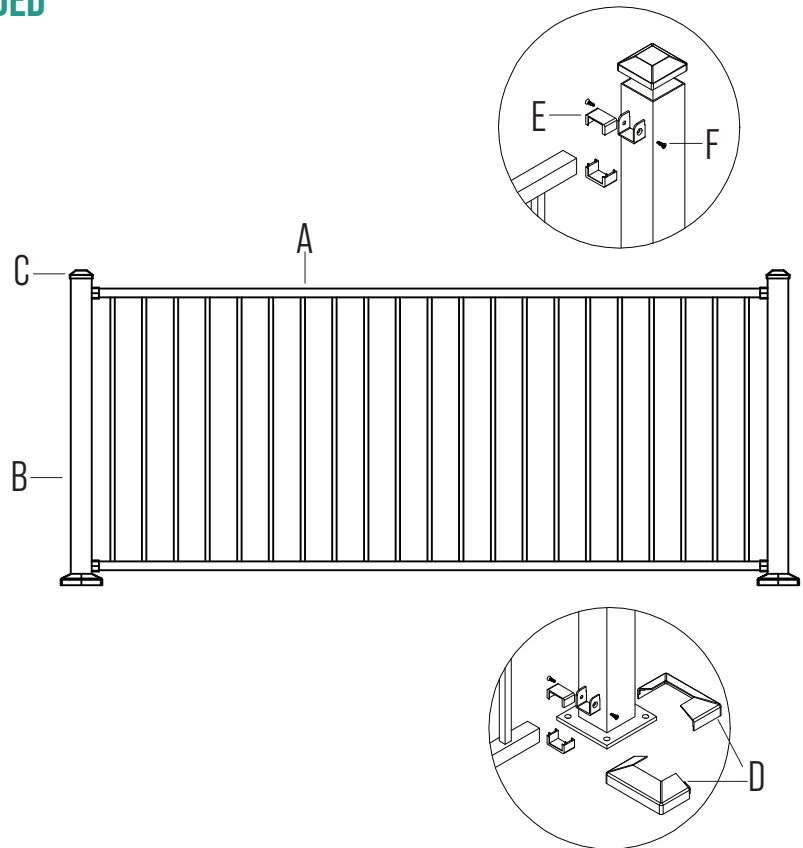

## - Material List of Level Steel Railing

PART NAME	IMAGE	NO.	QTY	REMARK
Panel		A	1	1 Panel installed with 2 Post kits
Pre- bracketed Post		B	1	Post Kit (Line/Corner/End)
Post Cap		C	1	
Post Skirt		D	1	
Rail/Bracket Cover		E	4	
Torx Head Screw*		F	8	M4.8x16mm Torx Head Screws (Use T25 Driver) * Screw Qty according to line/corner/end post.

### Notice:

This railing system comes with pre-mounted brackets, so note the following when positioning your posts:

- Mid / Line posts are used when you have railing on both sides in a straight line.
- Corner posts are used at 90-degree intersections.
- End posts are used when starting or ending a line of railing.



# Steel Railing Installation Instruction

## - Level Railing Installation

### STEP 1. Measure, Position and Secure Posts

- 1.1 Measure and position posts. Ensure posts are square and plumb. Use shims to adjust verticality.
- 1.2 Use 3/8" diameter fasteners to fasten posts according to local building codes (base plate holes are 1/2" in diameter).
- 1.3 Wood blocking must be installed with a minimum thickness of 1-1/2" where subframe doesn't exist. The internal spacing between posts is 72", 96" or 120" if full sections are used. Make sure your posts are positioned with panel lengths you are using.
- 1.4 After you have confirmed all squareness spacing between posts, secure to structure to local building code requirements.

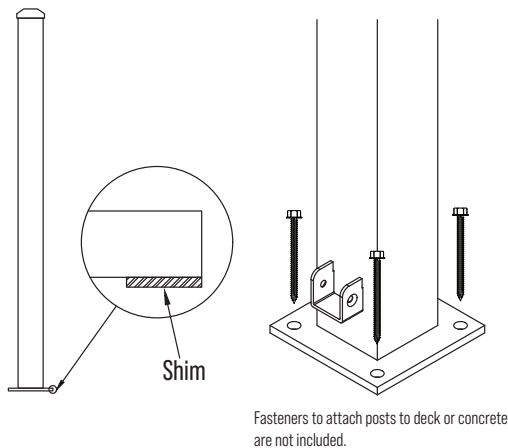

### STEP 2. Panel Cutting and Adjustment

- 2.1 Panels can be cut down to shorter sections if needed. Measure inside to inside of each bracket and ensure there is a 1/8" gap on each side of rail panel from post face to end of rail panel. This ensures flange on top bracket cover can securely seat between rail panel and post. Mark top and bottom rails. Cut equal amounts from each side to ensure proper spacing of balusters to posts.
- 2.2 Trim the top and bottom rails to length.
- 2.3 Remove all debris from cut area and paint with RailMaster Touchup paint, allowing area to dry completely.

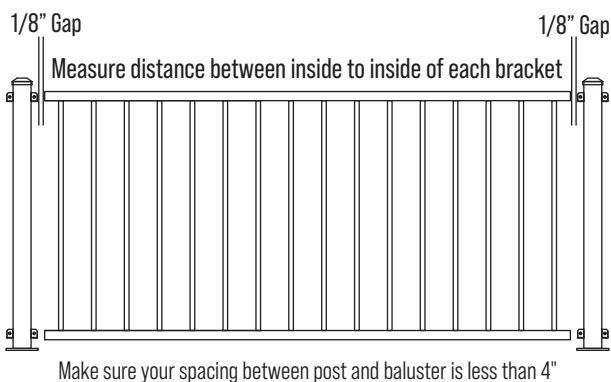

### STEP 3. Attach Panel to Brackets

- 3.1 Set the top and bottom rails into the brackets.
- 3.2 Pre-drill 1/8" pilot holes for Torx head screws for ease of securing panel to brackets
- 3.3 Use T25 Driver to secure panel to brackets with Torx head screws (included).
- 3.4 Place rail/bracket covers on top of rails and bottom of brackets, then snap pieces together. *NOTE: Top half of cover has flange that must go behind rail (against face of post). Bottom half of cover has four prongs to go into top half of cover. Make sure flange on bottom rail/bracket cover is on front side of bracket.*

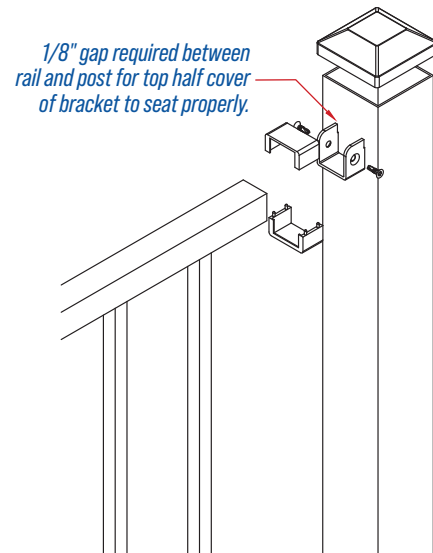

### STEP 4. Attach Post Skirt and Post Cap

- 4.1 Assemble the two sides of the post skirt over base of post and press together.
- 4.2 Place cap on top of post and use a rubber mallet to tap cap into place until it is securely fitted.

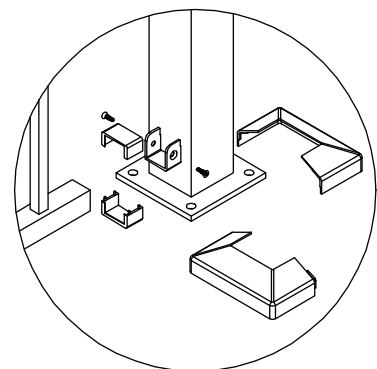

Continue to install each section of railing following your layout.



**PRE-INSTALLATION NOTE:** Stair installations can vary in terms of rise and run, post placement and post height. Carefully assess and lay out these details before permanently installing posts and cutting panels.

# Steel Railing Installation Instruction

## - Stair Railings

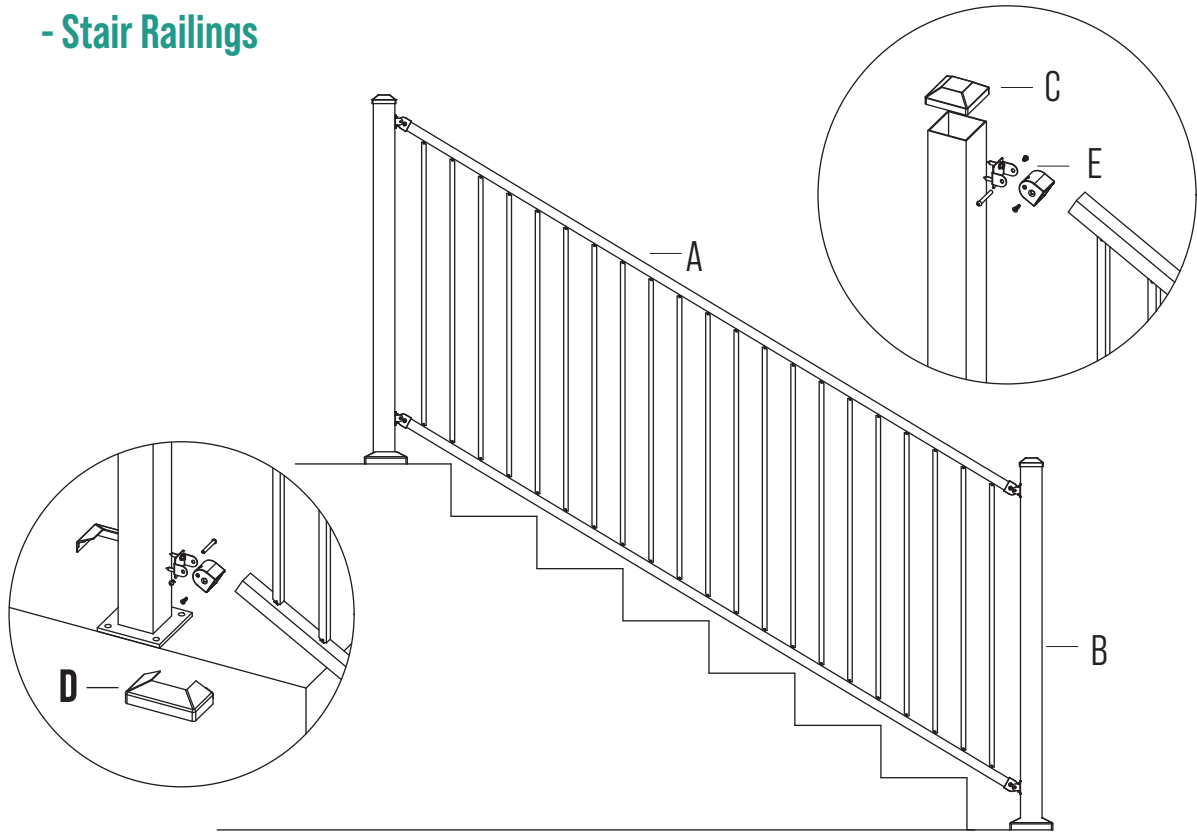

## - Material List - Stair Steel Railing

PART NAME	IMAGE	NO.	QTY	REMARK
Panel		A	1	
Blank Post		B	1	Blank Post Kit
Post Cap		C	1	
Post Skirt		D	1	
Angle Bracket Kit		E	4	Bracket has 2 parts - Post half - Rail half



# Steel Railing Installation Instruction

## - Stair Railing Installation

### STEP 1. Position Blank Posts

1.1 Ensure posts are square and plumb. Use shims to adjust verticality. Posts on both sides of stair rail panel should be aligned to each other.

1.2 Use 3/8" diameter fasteners to fasten posts according to local building codes (base plate holes are 1/2" in diameter).

1.3 Clamp stair rail panel to blank posts. Ensure spacing between posts and balusters at each end are equal.

Note: Blank posts available in 40", 44", 46" and 48".

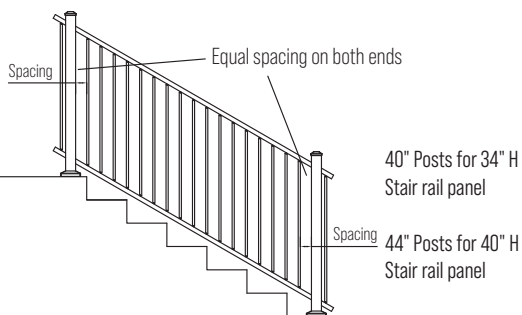

Check your local codes/ordinances for the proper spacing requirements from the bottom rail to the stairs as well as proper height requirements for the top rail.

### STEP 2. Position Brackets and Mark Location

2.1 Temporarily assemble the 2-piece angle brackets (post half and rail half). Position angle brackets on posts and mark location.

2.2 If cutting is required, equal amounts need to be cut from each side to ensure proper spacing of balusters to posts. For cut placement, mark panel from back of bracket. If length is properly cut, screw will fully secure rail and bracket together.

2.3 Cut the top rail and bottom rail.

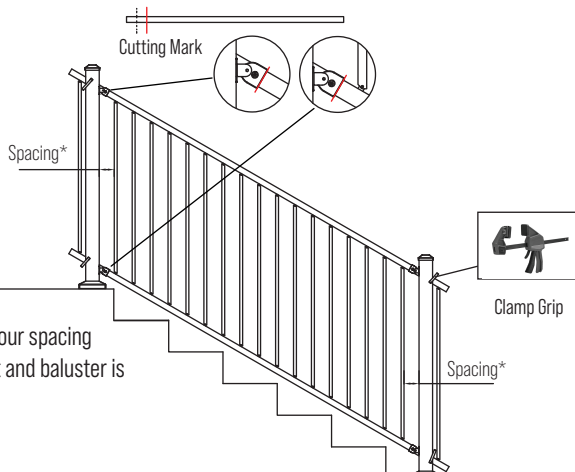

### STEP 3. Attach Angle Brackets to Posts

3.1 Separate the two parts of the angle bracket: post half and rail half.

3.2 Position post half of angle bracket on posts. Pre-drill pilot holes for post half of angle brackets using 5/32" drill bit.

3.3 Use 3/8" nut driver to attach post half of angle brackets to posts with ST6.3x25 screws (included).

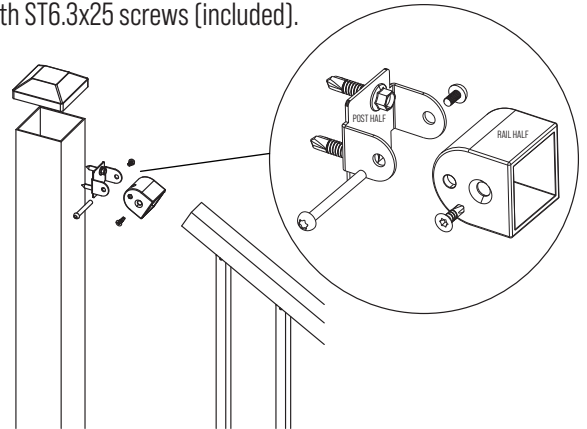

### STEP 4. Install the Railing to the Angle Brackets

4.1 Slide rail half of angle brackets over top and bottom rail ends (Don't secure until Step 4.4)

4.2 Connect both pieces of angle bracket together with M6x46 barrel bolt (included). Ensure panel is correctly in place and rail half of bracket properly overlaps top and bottom rail ends.

4.3 Use 5/32" drill bit to pre-drill pilot hole in top and bottom rails through pre-routed holes in rail half of angle bracket.

4.4 Use T25 Torx bit to drive ST 5.5x19 Torx head self-drilling screw into rail through rail half of bracket to secure assembly.

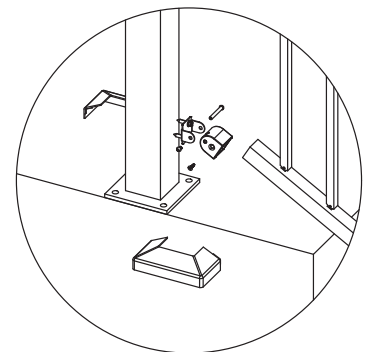

### STEP 5. Attach Post Skirt and Post Cap

5.1 Assemble the two sides of the post skirt over base of post and press together.

5.2 Place cap on top of post and use a rubber mallet to tap cap into place until it is securely fitted.

Make sure all screw connections for the stairs are secure and tight.



# Steel Railing Installation Instruction

## - Gate Uprights Assembly and Installation

### TOOLS:

- 5/32 Drill Bit
- Screwdrivers for M4.8 Hex head
- Metal Cutting Saw
- Rubber Mallet
- Eye Protection Glasses
- RailMaster Black Touch up Paint

### MATERIALS:

- Gate Uprights (includes 2 uprights and M4.8x3/4" Hex head screw) - 34" or 40" options
- Level Rail Panel (6', 8', or 10' options)
- Swing Gate Kit (includes 1 Latch & 2 Hinges)

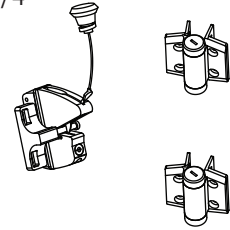

### STEP 1. Measure and cut the level rail panel

Level rail panel cutting length = Gate panel width requested - 2 1/4" x2 (see Pic. 5-C).

Gate Post distance = Gate panel width requested + 1 1/2" (For hinges and latch installation, see Pic. 5-A).

Note: A minimum of 1 1/2" and a maximum of 2 7/8" is required from the end of the level rail panel to the first baluster to install gate uprights (see Pic. 5-B). Cut the level rail panel and remove all metal shavings from the cut area. After cutting, it's important to paint the cut ends with RailMaster Touch up Paint and allow them to dry completely.

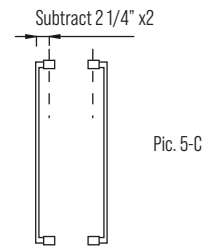
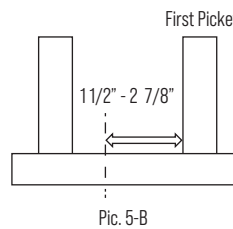
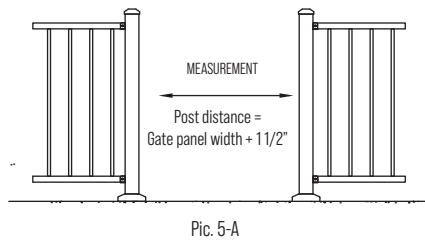

### STEP 2. Attach gate uprights to the level rail panel

Fully insert the gate uprights into the level rail panel, making sure the components are square. Pre-drill the screw holes at each corner of the level rail panel using a 5/32" drill bit (see Pic. 5-D). Secure the gate uprights to the level rail panel using the provided M4.8x3/4" Hex head screws.

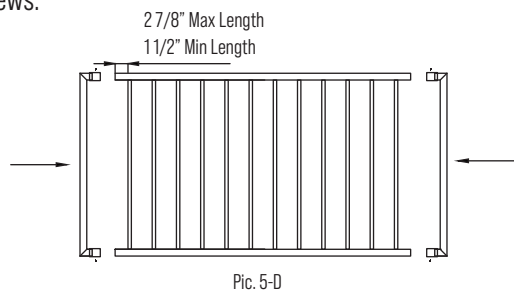

### STEP 3. Attach the gate with hinges and latch

Mark and drill holes to install the swing gate hinges to the post and gate at the desired height with the fasteners (M4.8x3/4" Hex head screw) included in the Gate Upright Kit.

It's important to attach the hinges in a way that prevents binding when the gate is folded.

Mark and drill holes to install the swing gate latch to the opposite post and gate at desired height with the fasteners (M4.8x3/4" Hex head screw) included in the Gate Upright Kit.



# Steel Railing Installation Instruction

## - Factory Assembled Gate Installation

### STEP 1. Measure the width of the gate opening

To utilize the 34-1/2" factory assembled gate, the gate opening between the posts should be 36" (see Pic. 5-E).

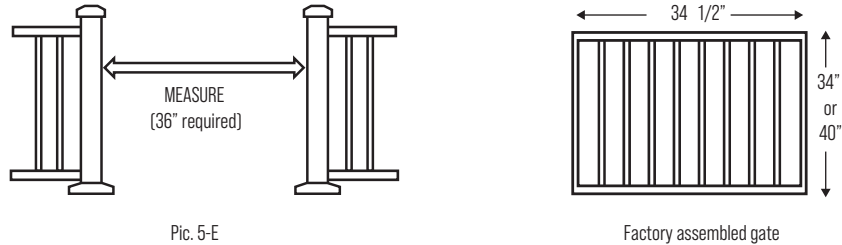

### STEP 2. Attach the gate with hinges and latch

Mark and drill holes to install the swing gate hinges to the post and gate at the desired height with the fasteners (M4.8x3/4" Hex head screw) included in the Gate Upright Kit.

It's important to attach the hinges in a way that prevents binding when the gate is folded.

Mark and drill holes to install the swing gate latch to the opposite post and gate at desired height with the fasteners (M4.8x3/4" Hex head screw) included in the Gate Upright Kit.

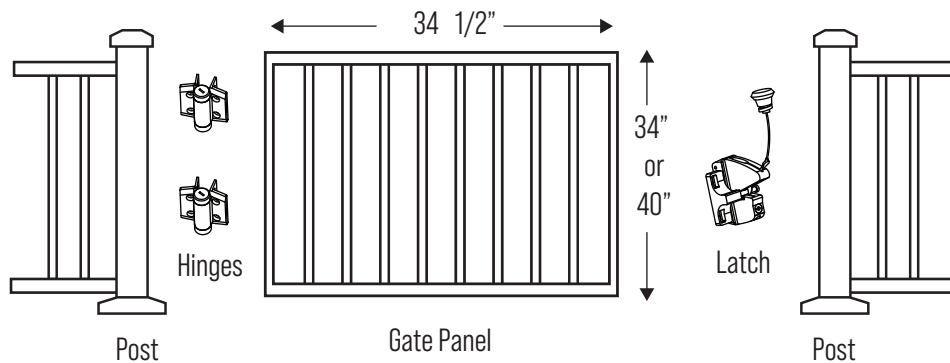

# Steel Railing Installation Instruction

## - Installing Bracket for Drink Rail

### TOOLS:

- 1/16" drill
- T25 Torx Bit
- Clamp grip x2

### MATERIALS:

- Drink rail bracket kit
- \* M4.8x5/8" Torx Head Lags included.

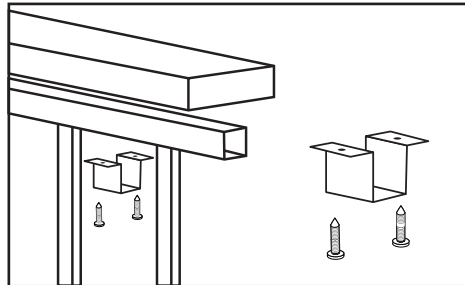

### STEP 1

Measure and cut the drink rail to the desired length.

### STEP 2

Center the drink rail on top of the rail panel and secure it with a clamp temporarily.

### STEP 3

Position the drink rail bracket no more than 6" from the post at each end of the drink rail (see illustration above). Using the bracket screw holes as a guide, mark the screw hole locations under the drink rail.

### STEP 4

Space additional drink rail brackets no more than 28" on center along the length of the drink rail and mark the remaining screw hole locations.

### STEP 5

Remove the drink rail and pre-drill the marks with a 1/16" drill, being careful not to drill through the drink rail.

### STEP 6

Reposition the drink rail on the panel and install the drink rail brackets using the supplied M4.8x5/8" Torx Head Lags.



# Steel Railing Installation Instruction

## - Install the Level Angle/Swivel Bracket onto a blank post or wood post

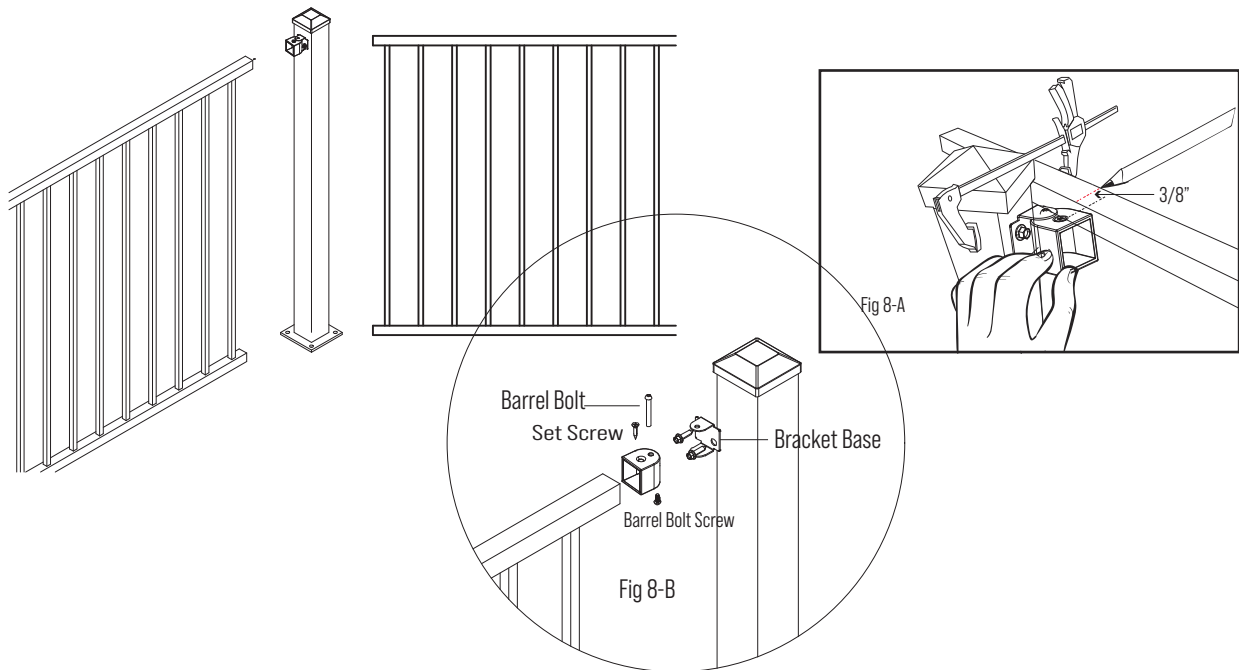

### STEP 1

Position the rail between two post so equal baluster spacing exists at each end and at the desired lower rail height as specified by local building codes. Clamp the railing to the post, position the level angle bracket against post face so the rail half of bracket lines up with the railing. (See Fig 8-A).

### STEP 2

Mark a line on the railing  $3/8$ " past the center of the set screw hole on the side of the bracket towards the post. Repeat at all rail ends. At the same time mark hole locations for the bracket plate to install onto post, making sure centered onto post.

### STEP 3

Pre drill these marked locations with a  $5/32$ " drill bit. Label top and bottom on the rail panel, then loosen clamps and remove panel for cutting. Cut rails where previously marked, paint cut ends of railing.

### STEP 4

Disassemble the level angle bracket by removing the barrel bolt screw (See Fig 8-B) and removing from assembly. Attach the bracket plate to the post with the provided  $\#10 \times 1$ " flat head sheet metal screw at the pre drilled locations.

### STEP 5

Place rail half of the angle level bracket onto 4 ends of the railing and reinstall the barrel bolt through the assembly at all 4 locations. Pre drilling with  $5/32$ " drill bit at set screw hole on the side of each bracket. Secure panel to bracket with provided set screw ( $\#10 \times 1$ " flat head sheet metal screw).

**IMPORTANT:** Every angle installation is different, so the post position and height must be carefully laid out before the post is permanently installed and the panels are cut.

